

KIDDE

COMMERCIAL

FIRE ALARM SYSTEMS.
POWERED BY PARTNERSHIP.*

FIRE ALARM SYSTEMS

EVOLVE-ML



NYC Fire Dept.
2025-TMCOAP-
004465-CERT



7165-1657-
0529



S3000

OVERVIEW

Kidde Commercial's Evolve Fire Alarm Systems are powerfully simple, simply powerful. Engineered for both advanced functionality and operational simplicity, streamlining installation, maintenance, and daily use. Offering features like intelligent detection, electronic addressing, automatic device mapping, and optional Ethernet connectivity, these systems deliver versatile solutions for building owners and installers.

The EVOLVE-ML panel includes a single Class A/B intelligent device loop, accommodating 250 device addresses. Loop controller modules can expand the system to 1,000 addresses in 250-address increments. The panel also features four Class A/B configurable Notification Appliance Circuits (NACs).

The RZ116-2 module enhances EVOLVE-ML systems, particularly for retrofits, by adding 16 conventional device circuits and two additional NACs, enabling the integration of intelligent detectors with existing conventional devices.

Evolve Series supports a wide range of high-end features, including:

- 10" LCD touchscreen display/user interface
- 10A switching power supply with Voltage Boost™
- Six programmable virtual switches and supports up to 72 physical switches with LEDs (optional) and custom labeling

FEATURES

- Supports intelligent modules and detectors
- Form C contacts for alarm and trouble, Form A for supervisory
- Electronic addressing with automatic device mapping
- Built-in Ethernet port for central station monitoring service, printing, local diagnostics and a variety of system reports
- Supports Genesis horn silence over two wires, and UL 1971-compliant strobe synchronization
- Supports GSA-REL releasing module for sprinkler control
- Ground fault detection by module
- Can use existing wiring for most retrofit applications
- Upload/download locally
- Built-in USB-C port for programming using the configuration utility on a technician's laptop
- Two-level maintenance alert reporting
- Pre-alarm and alarm verification by point
- Adjustable detector sensitivity
- Standalone operation
- Transmission test frequency by hour
- *Alarm ON* (functionality enabled using the EVOLVE-CU) command manually activates alarm condition
- Form C contacts for Alarm, Trouble (programmable), and Supervisory (programmable)

APPLICATION

Designed for the User

Evolve's simple and intuitive 10" touchscreen provides quick access to critical system functions such as system status, alarm silencing, and zone control. Displaying up to 8 events without scrolling eliminates menu navigation for technicians and facility staff. The touchscreen is customizable, allowing you to incorporate your company's logo.

Power Meets Possibility

The Evolve Series is designed for scalable growth, allowing you to easily adapt your system to growing facilities or changing layouts. Each panel supports up to 1,000 addressable devices. Built-In Ethernet port supports IP connectivity for monitoring services by a supervising station to meet NFPA 72 Chapter 26. The Ethernet port uses the FIBRO protocol to communicate with Sur-Gard System receivers (see Compatible DACRs chart for details). Effortlessly manage your system with six intuitive virtual programmable switches on the 10" touchscreen LCD, alongside an optional offering of 72 highly customizable switches and 72 multi-color (selectable in programming) LED indicators. Our innovative easily replaceable label design simplifies custom applications, delivering a clean and professional interface.

Upgrade Without Overhauling

The Evolve Series is engineered for seamless backwards compatibility, allowing you to upgrade your VS2 or VS4 system without replacing initiating and notification devices, wiring, or backboxes. This translates to significant cost savings and minimal downtime. The Evolve Series simplifies upgrades by eliminating the need to replace backboxes, cabinets, or disturb existing pipe and wire, including wall repairs. Leveraging standard wiring, Evolve removes the requirement for shielded cable, often enabling the reuse of existing wiring infrastructure. Evolve supports the RZH16-2 zone module, integrating up to 16 conventional circuits and two NACs, facilitating a smooth transition to intelligent detection while accommodating legacy systems.

Smarter Investment

The Evolve Series minimizes material and labor costs through simplified wiring topology and efficient programming software. The system supports extended wire runs, utilizing smaller gauge wire and negating the requirement for supplemental power supplies. Enhanced programming enables designers to accurately fulfill the building owner's unique system specifications.

The Complete System Designed for Simplicity

Intelligent Optica Detectors provide smart discrimination, differentiating between common nuisance particles like cooking smoke, dust, or steam, and actual fire hazards. System setup and maintenance are simplified with Electrical Mapping, which automatically links detector and module serial numbers to a visual layout. Electronic addressing eliminating manual dipswitch settings, ensuring precise device location. In addition, the inherent capabilities of Analog/Addressable Technology provide a robust foundation.

As the most energy-efficient appliances in their class of UL-listed notification devices, the Genesis™ LED series enables the use of smaller gauge wire, reducing installation costs. Offering even more flexibility, Evolve Series provides 13+ selectable notification appliance circuit (NAC) configurations suitable for a variety of settings and fully support the advanced synchronization and control of Genesis and Enhanced Integrity notification appliances. Genesis offers precision synchronization of strobes to UL 1971 standards. In addition, Genesis allows horns to be silenced while strobes on the same two-wire circuit continue to flash until the panel is reset. See

PROGRAMMING AND REMOTE DIAGNOSTICS

Kidde Commercial Evolve Series Fire Alarm Systems are simple to set up, yet offer advanced programming features that put small to medium sized building panels into a class of their own.

For more advanced system configuration and correlation groups programming, Evolve Series systems interface to a PC running compatible EVOLVE-CU software. This option offers full system configuration in the familiar Windows® operating environment. Connection is made to a laptop through the panel's built-in USB-C communications port. The Ethernet ports enable either a direct network connection or a connection via a cell communicator for central station monitoring, as well as connection to a system printer.

Available system reports include: Project, Loops, Groups, Correlations, Connectivity, Control/Display, Panel Status, Maintenance, Events, informational, and Device Details.

DIMENSIONS

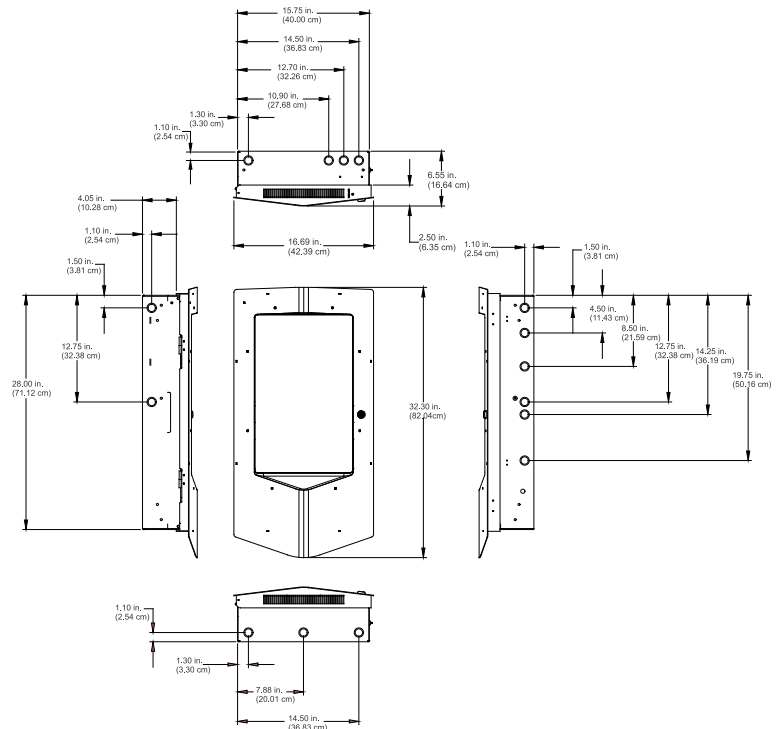

SYSTEM LAYOUT

EVOLVE-ML

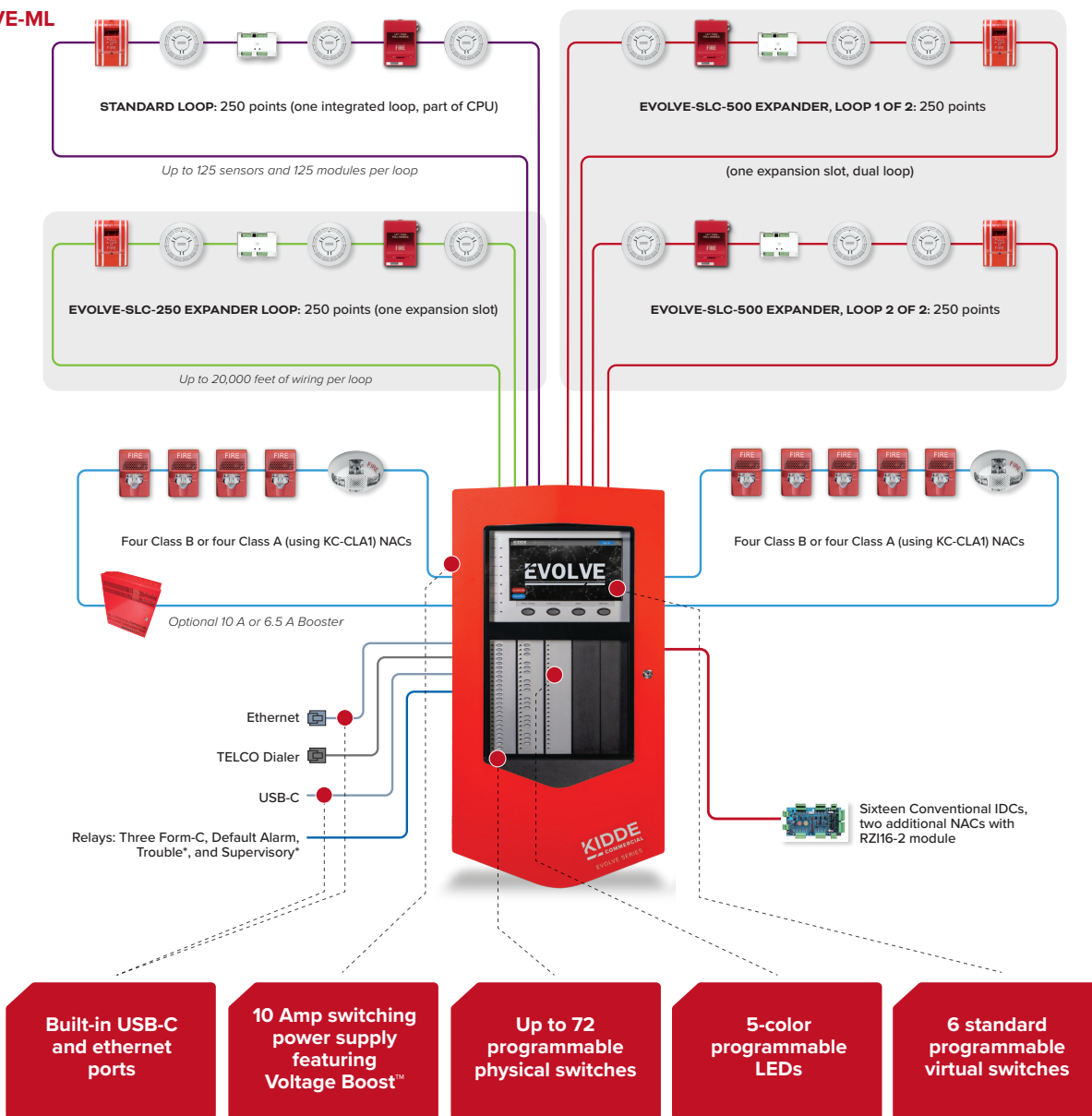

Each EVOLVE-ML panel has room for up to three additional device controller modules in any combination of single or dual device loops. EVOLVE-ML comes with one built-in loop that supports up to 125 detector and 125 module addresses.

PANEL LAYOUT

- 1 KC-PTK2 Trim Kit – Optional
- 2 Backbox (same height x width of VS2/VS4)
- 3 Holds up to two 18AH standby batteries
- 4 RZI16-2 Zone Card – Optional
- 5 Main Electronics Assembly – Power Supply & CPU
- 6 Inner Door Assembly with 10" Touchscreen LCD
- 7 LED/Switch Control Display modules – Optional
- 8 Outer EVOLVE Panel Series Door – Red or Grey

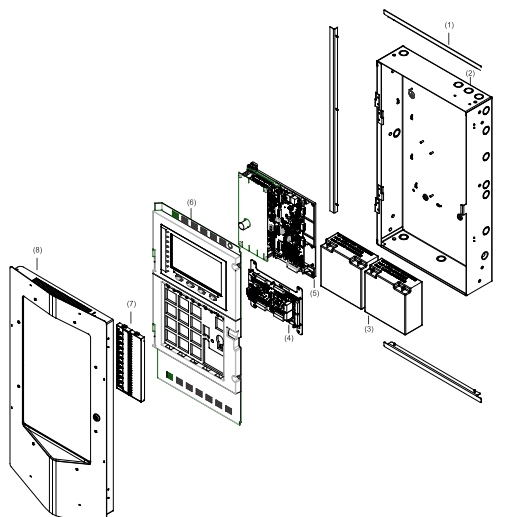

WIRING & CONFIGURATION

Device loop

The system provides one device loop circuit with a total capacity of 125 detectors and 125 module addresses. The loop circuit is supervised for opens, shorts, and grounds.

Circuit specifications	EVOLVE-ML
Device loops	One Class B or A loop, supporting 125 detectors and 125 modules. Expandable to four loops.
Communication line voltage	Maximum 21.0 V peak-to-peak
Circuit current	0.5 A max
Circuit impedance	100Ω total, 0.5 μF, max
Isolators	64 maximum
Signal Synchronization	(1) synchronization on CPU is between built-in notification appliance circuits (NACs) and built-in device loop #1. (2) Outputs on the expansion loop sync with other outputs on that same loop (i.e., GSA-CC1's used for NACs on Loop #2), not across loops.

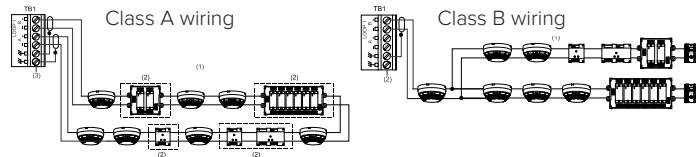

Notification appliance circuits (TB4)

EVOLVE-ML control panels come equipped with four notification appliance circuits. Each circuit can be individually configured for continuous, temporal, synchronized, and coded output.

Specifications	EVOLVE-ML
Circuit Type	4 Class B or 4 Class A (Use KC-CLA1 for Class A)
Voltage	24 VDC Filtered Regulated
Current	8.0 A total, 2.5 A max. (2.0 A when configured as AUX power) per circuit at 120/240 VAC 60 Hz.
EOLR	15 K Ω, ½ W
Signal Synchronization	(1) synchronization supported between built-in notification appliance circuits (NACs) and built-in device loop #1 on the CPU. (2) Outputs on the expansion loop sync with other outputs on that same loop, not across loops.

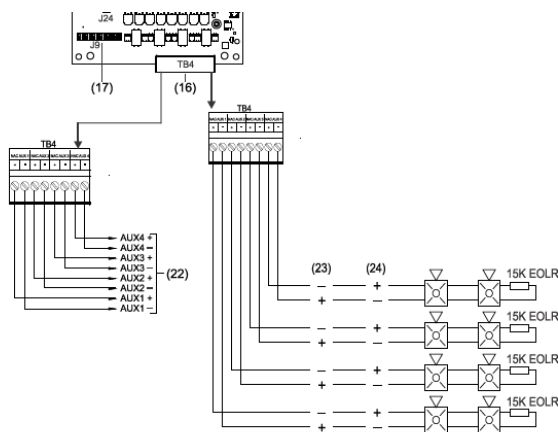

Marking indicates output signal polarity when the circuit is active. Polarity reverses when the circuit is not active. Wire notification appliances accordingly. Notification appliance polarity shown in active state.

Auxiliary & smoke power outputs (TB2)

The control panel provides two auxiliary power outputs that can be used for powering ancillary equipment such as two wire smoke detectors. The circuit is supervised for shorts and grounds.

Circuit specifications	
Circuit voltage range	21.9 to 28.3 V
Resettable circuit (Aux power 2)	24 VDC nominal at 500 mA
Continuous circuit (Aux power 1)	24 VDC nominal at 500 mA. Use this circuit for powering two-wire smoke detectors.

Note: Any current above 0.5 amp connected to both Aux 1 and 2 will reduce the total available NAC power by that amount.

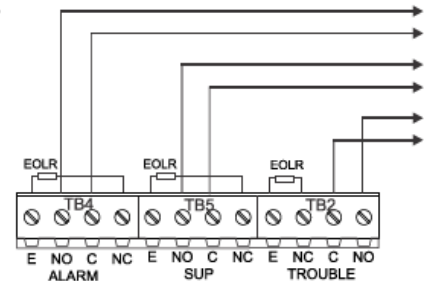

Alarm, trouble, and supervisory relay (TB2)

The trouble relay is normally-open, held closed, and opens on any trouble event or when the panel is de-energized. The supervisory relay is normally-open, and closes on any supervisory event. The alarm relay changes over on any alarm event.

Relay specifications

Common relays	
Current	
Standby	0mA at 24 VDC
Alarm/active	8 mA at 24 VDC
Quantity	3 (alarm, supervisory, trouble)
Type	Form C
Rating	30 VDC at 1.0 A, 1.0 PF
Wiring	Class E

Relay circuits can only be connected to power-limited sources.

OPTION CARDS

Kidde Commercial Evolve Series panels are supported by a complete line of modules and related equipment that enhance performance and extend system capabilities. Option cards plug directly into the control panel main circuit board or are connected to it with a ribbon cable. After installation, terminals remain accessible. The cabinet provides ample room for wire routing, keeping wiring neat at all times.

Single and Dual Loop Controller Cards

The EVOLVE-SLC-250 is a single loop controller card that can be used with the EVOLVE-ML as a 250-point expansion module.

The EVOLVE-SLC-500 is a 500-point dual loop controller card for the EVOLVE-ML that provides two SLC circuits, each with 125 detector addresses and 125 module addresses.

Specifications	EVOLVE-SLC-250	EVOLVE-SLC-500
Device Addresses	Evolve: one loop, 250 device addresses	Evolve: two loops, 500 device addresses
Wiring	Class B or Class A	
Operating Voltage	24 VDC	
Operating Current (fully loaded loop)	Standby: 65 mA (per loop) Alarm: 86 mA (per loop)	Standby: 110 mA (per loop) Alarm: 151 mA (per loop)
Note: These ratings do not include the use of two-wire smoke modules.		
Communication Line Voltage	Max. 21.0 V peak-to-peak	
Terminal Rating	12 to 18 AWG (1.0 to 4.0 mm ²)	
Circuit Current	0.5 A max.	
Max total loop resistance	100 Ω	
Max total loop capacitance	0.5 μF	
Isolators	64 isolators maximum per loop (total both isolator bases and modules)	
Ground Fault Impedance	0 to 5 kΩ	
Operating Environment	32 to 120°F (0 to 49°C) 0 to 93% noncondensing at 90°F (32°C)	

Built-In Ethernet Interface IP Communicator

Built-in ETH port provides a standard 10/100 Base T Ethernet network connection for connecting to an intranet, a local network, or the Internet. The interface supports IP connectivity for monitoring services by a supervising station to meet NFPA 72 Chapter 26. The Ethernet function uses the FIBRO protocol to communicate with Sur-Gard System receivers (see below). The interface can be used to download configuration programming from the EVOLVE-CU to the panel.

ETH specifications	
Ethernet	10/100 Base-T
Operating environment	
Temperature	32 to 120°F (0 to 49°C)
Humidity	0 to 93% RH, noncondensing at 90°F (32°C)
Compatible Sur-Gard Receivers	SG-System I, II, III, IV and 5

RZI16-2 Remote Zone Interface Module

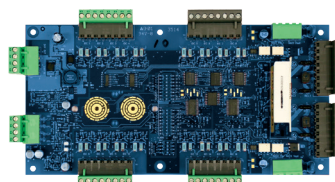

The RZI16-2 Addressable Remote Zone Interface Module is an addressable device that provides connections for sixteen Class B Initiating Device Circuits and two Class B Supervised Output Circuits. The inputs and outputs can be configured individually for several device types.

The RZI16-2 requires 18 consecutive addresses on the Signaling Line Circuit (SLC). Addresses are assigned electronically. There are no address switches to set.

The RZI16-2 incorporates two 8-segment DIP switches that are used to select the Alarm or Supervisory default device type for each of the 16 IDC circuits. The module also includes one 4-segment DIP switch used to select the default Relay or NAC output device type. Device types other than the default are accomplished through programming.

RZI16-2 Specifications	
Voltage/Current	
24V/Aux nominal:	24 VDC
Supervisory current:	250 mA at 24 VDC nominal
Alarm current:	1000 mA
24V/Aux minimum:	18.4 VDC
24V/Aux maximum:	26.4 VDC
NAC1, NAC2 nominal:	24 VDC
Current Per Circuit	
Standby current for 4.7 k EOL (U.S.)	4.8 mA/ circuit
Standby current for 3.9 k EOL (Canada)	5.7 mA/ circuit
Alarm current at nominal voltage	31.1 mA/ circuit
Relay outputs	
Quantity	2
Type Rating (pilot duty)	Programmable 24 VDC at 2.5 A
Input circuit wiring resistance	25 Ω per wire
Initiating device circuits	
Quantity	16
EOL resistor	4.7 kΩ (U.S.); 3.9 kΩ Canada
Zone voltage	23.9 V for 4.7 kΩ (U.S.) 23.02 V for 3.9 kΩ (Canada)
Alarm current	33.2 mA/ channel at nominal voltage 35 mA max
Alarm impedance range	< 680 Ω
Trouble impedance range	> 6.0 kΩ
Supervised output circuits	
EOL resistor	15 kΩ
Quantity	2
Short circuit detection	< 2.6 kΩ
Open circuit detection	> 66.0 kΩ
Contact ratings	24 VDC at 2.5 A (5 A for two NACs)
Compatible cabinets	MFC-A, EVOLVE-ML, APS

SA-DACT Dialer

The SA-DACT provides communications between the control panel and the central station over a telephone line system. It transmits system status changes (events) to a compatible digital alarm communicator receiver over the public switched telephone network. The dialer is capable of single, dual, or split reporting of events to two different account and telephone numbers.

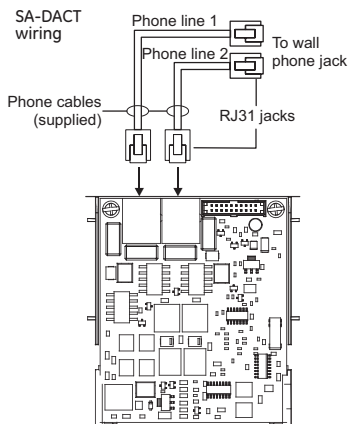

The dialer phone lines connect to connectors on the dialer's main circuit board. Phone line 1 connects to connector J4 and phone line 2 connects to connector J1.

The SA-DACT queues messages and transmits them based on priority (alarm, supervisory, trouble, and monitor). Activations are transmitted before restorations.

The SA-DACT is installed on the plastic assembly and connects to the main circuit board via a ribbon cable.

SA-DACT specifications

Phone line type	One or two loop-start lines on a public, switched network
Phone line connector	RJ-31/38X (C31/38X)
Communication formats	Contact ID (SIA DC-05)
Operating environment	
Temperature	32 to 120°F (0 to 49°C)
Humidity	0 to 93% RH, noncondensing at 90°F (32°C)

Compatible DACRs

Receiver	Models	Formats
Ademco	685	Contact ID
FBI	CP220	Contact ID
Osborne-Hoffman	OH 2000	Contact ID
Bosch	D6600	Contact ID
Silent Knight	9800	Contact ID
Sur-Gard	SG-MLR1, MLR2	Contact ID

KC-CLA1 Class A Module (EVOLVE-ML only)

The KC-CLA1 card provides Class A capability for NAC wiring. Its terminal block provides the wiring connection for NAC return wiring. EVOLVE-ML panels are Class A Ready. The KC-CLA1 is installed directly to the control panel circuit board using its plastic standoffs and plug connection.

KC-CLA1 specifications

Operating voltage	24V Filtered Regulated
Operating current	Max. Current 2.5 A per circuit (8.0 A total)
Terminal rating	12 to 18 AWG (1.0 to 4.0 mm ²)
Operating environment	
Temperature	32 to 120°F (0 to 49°C)
Humidity	0 to 93% RH, noncondensing at 90°F (32°C)
Standby	7 mA
Alarm	25.5 mA

EVOLVE-24L Series Control Display Modules

Kidde Commercial Evolve Panel Series are supported by a complete line of LED and Switch control display modules increasing versatility of the entire system. Each LED and Switch can be configured using the EVOLVE-CU to operate independent of each other or the Switch triggering the LED in a correlation. The LEDs are multi-color (Red, Yellow, Green, Blue, and White) and Switches configured for momentary and toggle, which enhance performance and extend system capabilities.

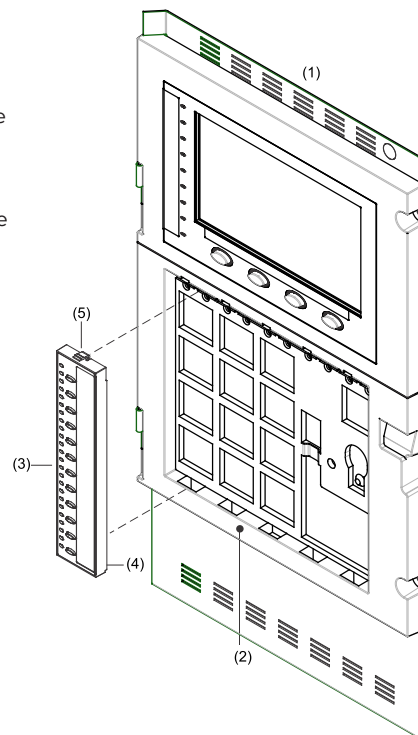

- (1) Inner door
- (2) UI frame assembly
- (3) Control-display module
- (4) Tab (bottom of module)
- (5) Locking tab (top of module)

ELECTRICAL SPECIFICATION

EVOLVE-ML	
Common relays	
Current	
Standby	0 mA at 24 VDC
Alarm/active	8 mA at 24 VDC
Quantity	3 (alarm, supervisory, trouble)
Type	Form C
Rating	30 VDC at 1.0 A, 1.0 PF
Wiring	Class E
Mains circuit	
Voltage	120/240 VAC, 50/60 Hz
Current	120 V, 50/60 Hz: 3.0 A max. 240 V, 50/60 Hz: 1.5 A max.
Brownout level:	≤ 95 VAC, 50/60 Hz ≤ 195 VAC (when operating at 230 V), 50/60 Hz
Wire size	12 to 18 AWG (1.0 to 4.0 mm ²)
Ground fault impedance	10 kΩ
Battery circuit	
Voltage	24 VDC nom.
Operating voltage	20.4 V min.
Charge current	1.5 A or 3.0 A, selectable
Battery capacity	65 Ah max.
Battery type	Sealed lead-acid
Expected standby operation	24 h min.
Operating environment	
Temperature	32 to 120°F (0 to 49°C)
Relative humidity	0 to 93% noncondensing

FIRE ALARM SYSTEMS.
POWERED BY PARTNERSHIP.*

CONTACT US

Phone: 888.244.9979 (Option 4)
Email: kidde.fire@carrier.com
Website: kidde-esfire.com

8985 Town Center Pkwy,
Bradenton, FL 34202

©2025 Walter Kidde Portable Equipment, LLC
All rights reserved.

*Kidde Commercial and its authorized resellers/
distributors are separate and independent entities.
This relationship between vendor and reseller/
distributor does not constitute a legal partnership or
create any shared liability between companies.

ORDERING INFORMATION

Part	Description
------	-------------

EVOLVE-ML Fire Alarm Systems

EVOLVE-ML-R	Four loop system with one built-in 250-point loop, 120V/240V, Red Door
EVOLVE-ML-G	Four loop system with one built-in 250-point loop, 120V/240V, Grey Door

Option Cards

EVOLVE-SLC-250	SLC Expansion Card, Evolve, Single, 250 PT, Kidde Commercial
EVOLVE-SLC-500	SLC Expansion Card, Evolve, Dual, 500 PT, Kidde Commercial
KC-CLA1	NAC Class A Conversion, Evolve Series, Kidde Commercial

Accessories

PT-1S+	System Printer
CTM	City Tie Module. 2-gang. Connection to a local energy fire alarm box
MFC-A	Multifunction Fire Cabinet, 8" x 14" x 3.5" - red
BC-1	Battery Cabinet. 14.0" x 18.25" x 7.25". Holds two 12V24A batteries
BC-1R	Battery Cabinet - Red. 14.0" x 18.25" x 7.25". Holds two 12V24A batteries
GSA-REL	Releasing Module
EVOLVE-24L	Display Module, 24 LED, Evolve Series, Kidde Commercial
EVOLVE-24L12S	Control Display Module, 24 LED/12 Switch, Evolve Series, Kidde Commercial
EVOLVE-24L18S	Control Display Module, 24 LED/18 Switch, Evolve Series, Kidde Commercial
EVOLVE-24L24S	Control Display Module, 24 LED/24 Switch, Evolve Series, Kidde Commercial
EVOLVE-FIL	Blank Filler Plate, Evolve Series, Kidde Commercial
EVOLVE-CPU-HDMI-CBL	Replacement HDMI Cable, CPU-to-LCD, Evolve Series, Kidde Commercial
EVOLVE-10TSLCD-RE	Replacement Touchscreen Display, Evolve Series, Kidde Commercial
EVOLVE-MB-RE	Replacement Electronics, Evolve Series, Multilingual, Kidde Commercial
EVOLVE-FPS-LK	Evolve, Language Kit - UI inserts for French Canadian, Spanish, Portuguese
KC-TAMPER	Tamper Switch, Evolve Series, Kidde Commercial
KC-PTK2	Panel Trim Kit, use on EVOLVE-ML panel series

Programming Tools

EVOLVE-CU	Evolve Series configuration and diagnostics utility
-----------	---